

---

## Effect of Television Advertising on Food Consumption among Children in Umuahia, Abia State, Nigeria

Dibie, V. M; Ukpai, K. U; Uwasomba, C. E. & Udeagha, K. K.

Department of Marketing  
College of Management Sciences  
Michael Okpara University of Agriculture Umudike,  
Abia State, Nigeria  
v.dibie@gmail.com

---

### **Abstract**

*The study examined the effect of television advertising on food consumption among children in Umuahia, Abia State. The specific objectives were to: examine the effect of television advertising jingle on food consumption among children; examine the effect of television advertising copy on food consumption among children; and examine the effect of television advertising setting on food consumption among children. The study adopted survey research design. A population of 115,934 parents in Umuahia North and South Local Government Areas, Abia State, were used for the study. Taro Yamane formula was used to determine a sample size of 400 from the population. However, 366 copies of the questionnaire were returned from the respondents which formed the valid copies used for the study. Primary data were sourced from the respondents (parents) in Umuahia North and Umuahia South Local Government Areas, Abia State. The hypotheses were tested using the simple regression model. Results from the study revealed that: (i) television advertising jingle has a significant effect on food consumption among children; (ii) television advertising copy has significant effect on food consumption among children; and (iii) television advertising setting has a significant effect on food consumption among children. A major recommendation from the study (among others) is that parents should teach their children how to react to television advertising jingles that relate to food consumption; as this will help to reduce the negative effect of jingles on children's demand for sweets.*

---

**Key Words:** *Television Advertising, Food Consumption, Children*

---

### **Background to the Study**

The media is one of the effective communication channels employed in marketing to spice up information dissemination process for goods and services. The media is categorized into print media (newspapers, magazines, catalogues, etc.), direct mail (direct official system used for delivering and receiving letters, packages etc., which may include, mail bag/post bag, among others; broadcast media (radio and television); and electronic media (electronic mails/emails, websites, audio tapes and posters etc), (Kotler, 1994).

It is important to note at this juncture that the media having the highest level of influence on children's food consumption and request behaviour appears to be advertising, especially television advertising, based on its audio-visual advantage (the use of sound and pictures simultaneously). Advertising is any form of non- personal communication through the mass media that is paid for by an identified sponsor. Advertising, along with sales promotion, personal selling, public relations and publicity forms the promotional/communications programmes of marketers (Nwokoye, 2000). Manufacturers and marketers use television advertisements that appeal to the different age groups of children, their mindsets and interests in specific products, to promote their brands (Hameed, Wagas Aslan, Bilal and Umair, 2014).

As members of the family, children have been categorized by various researchers and groups as follows:

Children according to Child Development Institute (1999) are categorized into:

- (i) Infants/ Babies (0 – 2yrs)
- (ii) Toddlers/Pre-Schoolers (2 – 5yrs)
- (iii) School Age Children (6 – 12yrs)
- (iv) Adolescents/Teenagers (13 – 17yrs)

For this study, however, the focus was on school age children (6-12years), (Child Development Institute, 1999). Children are socially active individuals, making decisions and responding in a specific manner to various social stimuli, such as appeals to food consumption (Douglas, 1998). Food is any substance consumed for the purpose of providing nutritional support for the body. In choosing any substance as food, an individual should first recognize it and classify it as appropriate for consumption according to his or her habits (cultural and nutritional among others), (Neto and Serafim de Melo, 2013). In this way, far beyond biogenetic factors, food choice relates to various socio-environmental factors (McNeal, 2002). In capitalist economies, children have great autonomy as consumers (Oliveira, 2003) in Neto and Serafim de Melo (2013). This autonomy seems to be having great influence on their purchase decisions and consumption pattern, especially in the area of food. Children now seem to be positioned in the consumer marketplace, to shop by themselves, especially for school lunch and snacks, making food decisions according to various influences among which television advertising appears to be chief. Marketers are capitalizing on this to bombard them with captivating advertising jingles, copies and settings to capture their emotions. In this regard, Camargo (2010), in Neto and Serafim de Melo (2013) suggested that consumer behaviour should be studied broadly starting with the consumer's interactions and seeking to understand his or her relationship with the environment.

In line with the narrative, different aspects of television advertising on food consumption appear to be affecting children in different ways. However, the aspects of television advertising focused on in this study include television advertising jingles, television advertising copies and television advertising settings; and their effects on food consumption among children examined.

Advertising jingles are short songs or tunes used in television advertisements, while advertising copy are the words, pictures or illustrations that make up the advertisement and advertising settings are the environments or effects portrayed in television advertisements (Nwokoye, 2000). In this study, the attention was on candy food or sweeties (sweet food containing sugar and chocolate, taken by children between meals, like sweets, candy cakes, candy drinks etc).

### **Statement of the Problem**

The marketing environment is characterized by competition and rapid changes in consumers' tastes. Consequently, television advertising has come a long way as a veritable communication tool marketers employ to disseminate relevant information about their brands to their target audience for the purpose of promoting such brands and with a view to attracting sales. To attract children, manufacturers and marketers of children's food products now invest heavily on television advertisements that appeal to the different age groups of children, their mindsets and interests on specific products, (Hameed, Wayas Aslam, Bilal and Umar, 2014). As manufacturers and marketers of children's food products are employing captivating television advertising with marvelous jingles, copies and settings to capture the interests and emotions of children and are making good money out of it by way of increased sales revenue and profit, little or no attention is given to the side effects suffered by the children on that account. How good is this?

As it stands today, children spend several hours every day watching different television programmes including advertisements on food that appeal to their age, interests and emotions (Klein *et al.*, 1993). When children watch television advertisements that have strong appeal for their age, interests and emotions, they persuade their parents to purchase the products advertised for them (Dibie, 2017). Children now appear to be overreacting to television advertising on food by way of making excess demand for such food from parents. Some parents are as well overreacting to television advertising on food by way of approving such excess demands and making provision for such food for children (Furham, Abramsky and Gunter, 1997; Powell Szez and Chaloupka, 2007). Against this backdrop, this study particularly sought to examine the effect of television advertising jingle, television advertising copy and television advertising setting on food consumption among children. The specific objectives of the study were to:

- i. Examine the effect of television advertising jingle on food consumption among children;
- ii. Examine the effect of television advertising copy on food consumption among children, and
- iii. Examine the effect of television advertising setting on food consumption among children.

### Research Questions

The key research questions for this study were:

- (i) How does television advertising jingle affect food consumption among children?
- (ii) How does television advertising copy affect food consumption among children?
- (iii) How does television advertising setting affect food consumption among children?

### Research Hypotheses

The following hypotheses were tested in the course of the study:

- H<sub>01</sub>:** television advertising jingle has no significant effect on food consumption among children.
- H<sub>02</sub>:** television advertising copy has no significant effect on food consumption among children.
- H<sub>03</sub>:** television advertising setting has no significant effect on food consumption among children.

### Significance of the Study

This study would be quite significant in terms of those it would benefit and how it would benefit them. The study would benefit children, parents, manufacturers and marketers of children's food, scholars and researchers.

On the one hand, the study would help children understand the dangers associated with spending too much time watching television and overreacting to television advertisements on food. On the other hand, the study would help parents find ways of regulating their children's and wards' general attitudes toward watching television programmes and advertisements on children's food with a view to curtailing them. Moreover, the study would help manufacturers and marketers of children's food understand the need for ethical advertising aside buyer inducement. Finally, the study would serve as reference material for scholars and researchers who may wish to go into studies in related areas.

### Scope of the Study

The study examined the effect of television advertising on food consumption among children. The study was carried out in Umuahia, Abia State, Southeast Nigeria. The study targeted

parents, as they have a relatively high population in the area for data generation, since they have custody of the children and are not likely to give biased information about them.

## Review of Related Literature

### Conceptual Framework

The model to guide this study is presented as follows:

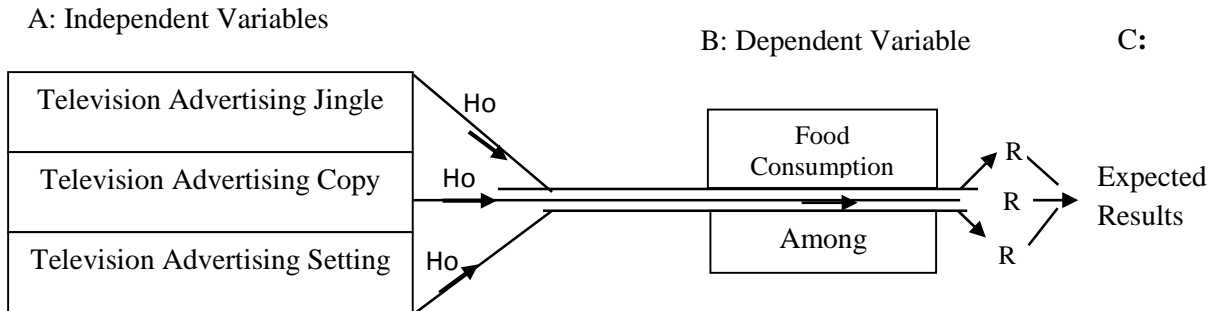
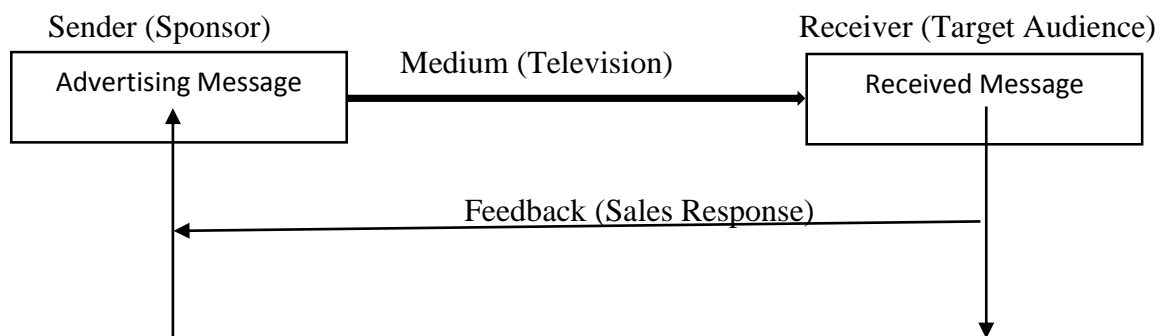

**Figure 1: Variables of the Study**  
Source: Researcher's Model (2018).

The model is comprised of three parts (A, B and C). While part "A" represents the independent variable (which are by proxy television advertising jingle, television advertising copy and television advertising setting); part "B" represents the dependent variable, which is food consumption among children; and part "C" denoted by "RRR" represents the expected results of the study.

### The Concept of Television Advertising

A television advertisement is a span of television programming produced and paid for by an organization, which conveys a message typically to market a product or service. Advertisers and marketers may refer to television advertisements as TVCs (Yesser and Faisal) in Vimi (2013), Nwokoye (2000). A sample television advertiser's communications depicting how advertising and marketers disseminate relevant information (messages) about products and services is presented as follows:



**Figure 2: A Simple Television Advertising Communication Model**  
Source: Adapted from Nwokoye (2000)

Based on the model, the relevant information about a specific product or service is packaged as advertising message by the sender (sponsor).

---

---

### **Television Advertising Jingle and Food Consumption among Children**

Advertising jingles are short musical compositions normally written specially for the advertisement of specific brands/products. Generally, they have a catchy tune and lyrics and are used repeatedly in different commercials and promotions of the company, so as to encourage consumer recognition and retention (Nwokoye, 2000; Hoerberichts, 2012). Advertising jingles can be used to attract the listeners' attention; carry that advertised product's message and act as mnemonic device. As a mnemonic device, an advertising jingle being a spread kind of music specially but together for a specific brand, helps the listener to associate the brand with the jingle which eventually makes the listener to remember the brand anytime he sees the advertisement on television.

The musical lyrics and melodies in jingles interact and help listeners retain lyrical information about the advertised brand/product in their long-time memory (Wallace, 1994). The Jingle is encoded in the listener's brain where it can be late retrieved through memory recall. Children as result if this have the habit of singing along with the song. This help produces a powerful effect on their emotions, grabbing their attention and further causing them to identify the product with the message being conveyed for purchase and consumption considerations. Television advertising jingles is therefore an effect way to communicate a concept or an idea in a memorable way (Yalch, 1991), especially to children. Children's food vendors are interested in the buying power of children for food that captures their age interests and emotions. The vendors therefore spice up their television advertisements on such food products with captivating jingles and is working for them. Children now rush to shops to buy the products, singing the jingles they have associated with the food products. This perhaps account for what most of the food products demanded for and consumed by children are those they have watching their advertisements on television.

### **Television Advertising Copy and Food Consumption among Children**

Advertising copy are the words, pictures or illustration that make up the advertisements for different brands/products. Many television advertisements feature slogans and catchy phrases designed to be striking and memorable. Advertising slogans are short often memorable words phrases used in advertising campaigns (Council for Cable Information, 1984). These slogans and catchy phrases may even remain in the minds of television viewers long after the span of the advertising campaign. Some of these slogans and catchy phrases come with special illustrations depicting unique lifestyles and spawning gags as can be seen in films, television shows, magazines, comics or literature (Wikipedia). These long-lasting advertising elements may be said to have taken a place in the pop culture history of the demographic targeted, children in this case. Children often mimic such words or phrases when they hear them and are emotionally moved by them to go for the food products they are used to advertise.

The pictures can vary from hand-drawn traditional animation or cartoons. By using animated characters, an advertisement may have a certain appeal that is difficult to achieve with actors or mere product displays. Animation is also used in advertising. Animated advertising is a recognized link between high levels of exposure to advertising of unhealthy foods and overweight and obesity among children (Kelly, Hattersley, King and Flood, 2008).

### **Television Advertising Setting and Food Consumption among Children**

Most television advertisement on children's food based on the audio-visual power of television, portray settings characterized by abundance, influence and power among others. Advertising settings are the animations or effects portrayed in Television advertisements (Nwokoye, 2000). Children that are featured in such advertisements appear to be children from financially comfortable homes that can get "everything" at their "beck and call". The advertisement portray settings devoid of poverty or lack, making it look like there are no poor families or poor

children anywhere in the world. By implication, the settings portrayed in children's food advertisements television influence attitude development among children negatively (Nwokoye, 2000).

According to Blackwell, Miniard and Engel (2006), attitudes are defined as being "global or overall evaluative judgements". Since attitudes influence purchase intent and purchase behavior, it is of great interest to marketers and advertisers what consumers think about their products; whether they are favorable toward such products or whether the products are of the best qualities or not. For Petty and Cacioppo (1986), attitudes imply general evaluations people hold regarding themselves, other people, objects and issues. These evaluations can be based on an array of emotional, behavioral and cognitive experiences with the product service or brand. In addition, they can affect or steer emotional behavioral and mental activities. Television advertisements on food, for children from poor homes, television advertisement on food, in certain situations, appear to be contributing immensely to family conflicts or children-parents conflicts. Situations where children pressurize parents to purchase certain products for them and the parent's refusal swing them to anger and trouble starts (Asadouahi and Tanha, 2011). Some children fail to understand the truth that the influence children have on the decision making in their family may vary across different types of families, particularly in an emerging market context (Alam and Khalifah, 2009). Such children, based on the deceptive settings portrayed in some advertisements may begin to find ways to sit into such settings, thereby learning pilferage, lie telling and other irritating behaviors.

### **Effect of Television Advertising on Children's Food Buying Behaviour**

Children naturally love watching television programmes especially such programmes that appeal to their age, interests and emotion. This perhaps accounts for why most families even in our local communities, these days make effort to have television sets in their homes. Among the programmes, television advertisements seem to have much grip on children especially television advertisements on food substances, like sweeties. Hameed, Waqas, Aslam, Bilal and Umair (2014) suggested on food:

- i.** Television advertisements have strong influence on children's buying behavior;
- ii.** At certain age laments children may be easily influenced by what they see and television advertisements on food have much for them to see in this regard.
- iii.** Children who spend much time watching television advertisements at some points develop new buying behavior that favour products frequently advertised which in a way have captured their age interests and emotions. The effect of television advertisements on children buying behavior has become a topical issue in Europe, America, even in Nigeria and other developing countries in recent times. Many researchers have indeed devoted much resources in this area of research. It should be noted here that children may only be interested in acting in favour of food products frequently advertised by why of sharing interests in the products and requesting their parents to purchase the products for them, with little or no information about the dangers associated with over-consumption of some of such food products which may basically be junk foods. Commercial food advertising to children basically include breakfast cereals, sugar, snacks, non-alcoholic beverages and fast food restaurants (Buijzen, Schuurman and Bomliof, 2008). Food substances mostly advertised for children all over the world are more of sweeties, with much sugar, fat and oil, responsible for the problems of child obesity (Asudollahi and Yanha, 2011).

Moreover, most food advertising scenes on television capture the lifestyles of the parent and affluent children from there children whose parents may not be able to afford such flaubuoyant lifestyles learn how to pressurize parents to either purchase what they see on the advertisements

for them or immediate the lifestyle portrayed. In many instances, may children in deep having problems with their parents who may not be able to meet their necessary demands?

### **Theoretical Framework**

This study was anchored on the Elaboration Likelihood Model (ELM) of Persuasion and the Theory of Musical Fit.

### **The Elaboration Likelihood Model (ELM) of Persuasion**

The Elaboration Likelihood Model (ELM) of Persuasion was developed by Petty and Cacioppo (1986). The model essentially summarizes the different cognitive processes that were found by earlier studies. The ELM is a general framework for organizing, categorizing and understanding the basic processes underlying the effectiveness of persuasive communications. For this paper, persuasive communication implies advertisements (television advertisements). The model proposes that there are two routes in which attitudes can be shaped or changed. The first route is called the central route. When a person has the opportunity, capability and incentive to carefully process the information of a certain product or brand, attitudes are typically influenced through the central route. This involves situations where a consumer exhibits high involvement like cars, where one has to assess and consider many aspects of the product before buying it. The second route is called the Peripheral route. Through this route, attitudes are less affected by active thinking but more by indirect subliminal factors. This is more likely with low involvement products, where one may not need much product information such as bottled water and sweeties, in the case of children.

Petty and Cacioppo (1986) referred to high involvement situation as one with high elaboration likelihood and the low involvement situation as one with low elaboration likelihood.

### **Implication of the ELM to this Study:**

Some types of persuasive communication take place when a person (a child in this case) watches a television advertisement. If the person is motivated and has the right ability to process the message, it can induce an attitude change either positively or negatively. If favorable thoughts predominate when the person watches the advertisement, a positive attitude change can occur. However, when unfavorable thoughts predominate, a negative attitude change can occur. This most times is the case when children watch television advertisements on food and are get carried away by the settings. These setting most times, directly or indirectly depict situations that most families cannot afford, yet many children based on such settings develop negative request behavior. Many parents most times find it difficult to meet up with such requests and troubles start from there.

### **Empirical Review**

Two studies considered relevant to this study that were reviewed are highlighted as follows: The study carried out by Hameed, Waqas, Aslam, Bilal and Umair (2014) in Punjab Pakistan, to investigate the impact of television advertisements on children's food buying behaviour. The study adopted the use of questionnaire to collect data randomly from 250 children of different age brackets across different schools in different cities of Punjab, Pakistan. Data were analyzed through the use of descriptive statistics, correlations, regressions and analysis of variance (ANOVA). The results from the study indicated that all the children agreed with the following hypothesis:  $H_{A1}$ : Age has a positive correlation with children's buying behavior

$H_{A2}$ : Television viewing hours has a positive relationship with children's buying behavior

$H_{A3}$ : Food advertisements have a positive relationship with children's buying behavior

$H_{A4}$ : Television advertisements have a positive relationship with children's buying behavior

$H_{A5}$ : Rock music has a positive relationship with children's buying behavior

**H<sub>A6</sub>:** School advertisements have a positive relationship with children's buying behavior. These results show that the age of children has influence on their buying behavior. At certain age brackets, children make demands for certain products and their demand pattern tends to change as they grow older; and the number of hours children spend watching television advertisements influence their buying behavior. It is most likely that children who spend more hours watching television advertisements for specific products/services that appeal to them make more demands for such products/services than children who spend less hours watching television advertisements for such products/services. This study did not indicate whether television advertisement have negative implications in children.

The study carried out by Letona, Chacon, Roberto and Barnoya (2014) in Guatemala in Central America, to determine the effect of taste on children's purchase decision for snacks. 37 children of 7 – 12 years were interviewed. Results from the study revealed that children most times like to buy salty snacks; and that most children select their products based on how they perceive the tastes of the products. The study did not indicate whether excess consumption of salty snacks have any negative health implication on children. Such indication would help perhaps guide their children on consumption of such products.

### Methodology

The study which adopted the survey research design was conducted in Umuahia (comprising Umuahia North Local Government Area and Umuahia South Local Government area) Abia State, Nigeria.

### Population of the Study

The population of the study was composed of married persons (males and females) considered as parents, and believed to be having children/wards of ages 6-12 years, directly living with them.

**Table 1: Population of Parents in the Study Area**

LOCAL GOVERNMENT AREA (LGA)	POPULATION
Umuahia North LGA	71,303 (61.50%)
Umuahia South LGA	44,631 (38.50%)
TOTAL	115,934(100%)

Source: Adapted from National Population Commission (2006)

### Determination of Sample Size

The sample size was determined using the Yamane (1967) sample size determination formula stated as follows:

$$n = \frac{N}{1 + N(R^2)}$$

Where: n = Sample Size  
N = Study Population  
1 = Constant  
R = Error Margin (5%)

Where: N = 115,934  
1 = 1  
R = (0.05)<sup>2</sup> = 0.0025  
Study population = N = 115,934



### Sample Size

$$\begin{aligned}n &= \frac{115,934}{1 + 115,934(0.05^2)} \\ &= \frac{115,934}{115,935 \times 0.0025} \\ &= \frac{115,934}{289.8375} \\ &= 399.99 \cong 400\end{aligned}$$

Therefore, a total of 400 parents constituted the sample size for the study.

### Research Instrument

A well-structured questionnaire was the measuring instrument for this study. The questionnaire contained two sections, (Section A and Section B). Section 'A' contained respondent's demographic characteristics while Section 'B' contained structured statements based on the objectives of the study. The responses had numerical values in terms of point(s) attached to them in a five-point Likert type scale as follows: Strongly Agree (SA) = 5; Agree (A) = 4; Disagree (D) = 3; Strongly Disagree (SD) = 2; Indifferent (I) = 1.

### Administration of the Instrument

A total of 400 copies of the structured questionnaire were randomly administered by the researcher to the respondents within the study area. Out of this total, 61.50% (246 copies) were randomly administered to respondents in Umuahia North Local Government Area, while 38.50% (154 copies) were randomly administered to respondents in Umuahia South Local Government Area.

### Validity and Reliability of Instrument

The instrument was validated appropriately and the test-re-test reliability carried out using the Cronbach's Alpha to ascertain the coefficient of the two test conducted.

### Data Analysis Techniques

The Descriptive Statistics were used to analyze respondents' demographic characteristics. The Simple Regression Technique was used to test hypotheses. All analysis were carried out through the application of the Statistical Package for Social Sciences (SPSS 22.0 Version) and results interpreted appropriately.

### Model Specification

The Simple Regression formular is given as follows:

$$Y = b_0 + b_1x \text{ (Nurudeen and Ojoawo, 2001)}$$

Where Y = Dependent Variables (Food Consumption among Children)

X = Independent Variables (Television Advertising Jingle, Television Advertising Copy, and Television Advertising Setting)

## Results and Discussions

### Response to Questionnaire Administered

**Table 2: Returned copies of Questionnaire**

Respondents	No. of copies Administered	%	No. of copies Returned	%	Not returned	%
Umuahia North LGA	246	61.5	227	56.8	19	4.7
Umuahia South LGA	154	38.5	139	34.7	15	3.8
<b>Total</b>	<b>400</b>	<b>100</b>	<b>366</b>	<b>91.5</b>	<b>34</b>	<b>8.5</b>

**Source: Field Survey, 2018**

As shown in Table 2, a total of 400 copies of the questionnaire were administered, Umuahia North LGA (246: 61.5%) and Umuahia South LGA (154: 38.5%). Out of this number, returned copies were: Umuahia North 227 (56.8%) and Umuahia South LGA 139 (34.7%). Making a total 366 respondents that constituted the sample size for the study.

### Presentation of Data

**Table 3: Effect of Television Advertising Jingle on Food Consumption among Children**

**Objective One:** To Examine the Effect of Television Advertising Jingle on Food Consumption among Children.

	SA	A	D	SD	I	Total
1. Children mostly demand for and consume food products they easily remember with their advertising jingles	183 50.0%	112 30.6%	37 10.1%	22 6.0%	12 3.3%	<b>366</b> <b>100</b>
2. Children mostly demand for and consume food products whose jingles capture their interest and emotions.	190 51.9%	102 27.9%	42 11.5%	11 3.0%	21 5.7%	<b>366</b> <b>100</b>
3. Children tend to demand for and consume excess sweets that may have negative implications on their health as a result of the captivating jingles in the advertisements of sweets	228 62.3%	90 24.6%	31 8.5%	7 1.9%	10 2.7%	<b>366</b> <b>100</b>

**Source: Field Survey, 2018.**

From the table, 62.3% of the respondents strongly agreed that children tend to demand for and consume excess sweets that may have negative implications on their health as a result of the captivating jingles in the advertisements of sweets as against 1.9% who strongly disagreed. Meanwhile, 51.9% strongly agreed that children mostly demand for and consume food products whose jingles capture their interests and emotions as against 3.0% who strongly disagreed. Also, 50.0% of the respondents strongly agreed that children mostly demand for and consume food products they easily remember with their advertising jingles as against 6.0% that strongly disagreed.

**Table 4: Effect of Television Advertising Copy on Food Consumption among Children**  
**Objective Two:** To Examine the Effect of Television Advertising Copy on Food Consumption among Children.

	SA	A	D	SD	I	Total
1. Children are easily attracted to food products advertised with catchy slogans or phrases that appeal to their interests and emotions.	231 63.1%	109 29.8%	17 4.6%	4 1.1%	5 1.4%	<b>366</b> <b>100</b>
2. Children are easily attracted to food products whose advertisements showcase unique illustrations that appeal to their interests and emotions.	149 40.7%	161 44.0%	34 9.3%	13 3.6%	9 2.4%	<b>366</b> <b>100</b>
3. Children are easily attracted to food products advertised with animated characters that appeal to their interests and emotions.	215 58.7%	124 33.9%	11 3.0%	10 2.7%	7 1.6%	<b>366</b> <b>100</b>

**Source: Field Survey, 2018.**

From the table, majority of the respondents (63.1%) strongly agreed that children are easily attracted to food products advertised with catchy slogans or phrases that appeal to their interests and emotions as against 1.1% that strongly disagreed. Meanwhile, 58.7% also strongly agreed that children are easily attracted to food products advertised with animated characters that appeal to their interests and emotions as against 2.7% that strongly disagreed. Finally, 44.0% of the respondents agreed that children are easily attracted to food products whose advertisements showcase unique illustrations that appeal to their interests and emotions as against 9.3% that disagreed.

**Table 5: Effect of Television Advertising Setting on Food Consumption among Children**  
**Objective Three:** To examine the effect of television advertising setting on food Consumption among Children.

	SA	A	D	SD	I	Total
1. Most television advertisements for food portray deceptive settings that result in negative attitude development like pilferage and lie telling among some children; with respect to food purchase and consumption	177 48.4%	145 39.6%	32 8.7%	8 2.2%	4 1.1%	<b>366</b> <b>100</b>
2. Most television advertisements for food products portray deceptive settings that make children demand for and consume excess junk food.	198 54.1%	139 38.0%	16 4.4%	13 3.5%	-	<b>366</b> <b>100</b>
3. Most television advertisements for food products portray deceptive settings that make children demand for and consume food indiscriminately.	222 60.7%	133 36.3%	9 2.4%	-	2 0.6%	<b>366</b> <b>100</b>

**Source: Field Survey, 2018.**

From the table, most of the respondents (60.7%) strongly agreed that most television advertisements for food products portray deceptive settings that make children demand for and consume food indiscriminately. Also, 54.1% of the respondents strongly agreed that most television advertisements for food products portray deceptive settings that make children demand for and consume excess junk food as against 3.5% who strongly disagreed. Finally, 48.4% strongly agreed that most television advertisements for food portray deceptive settings

that result in negative attitude development like pilferage and lie telling among some children as against 2.2% who strongly disagreed.

**Table 6: Effect of Television Advertising on Food Consumption among Children**

**Broad Objective:** To examine the Effect of Television Advertising on Food Consumption among Children.

	SA	A	D	SD	I	Total
1. Captivating television advertising jingles for food make children demand for and consume excess food that may have negative implications on their health	217 59.3%	116 31.7%	21 5.7%	12 3.3%	- -	<b>366</b> <b>100</b>
2. Catchy television advertising slogans and illustrations for food misguide children when making demands from parents, with respect to food purchase and consumption	215 58.7%	123 33.6%	13 3.6%	7 1.9%	8 2.2%	<b>366</b> <b>100</b>
3. Deceptive television advertising for food results in negative attitude development like pilferage and lie telling among children, with respect to food purchase and consumption.	196 53.6%	154 42.1%	10 2.7%	- -	6 1.6%	<b>366</b> <b>100</b>

**Source: Field Survey, 2018.**

From the table, 59.3% of the respondents strongly agreed that captivating television advertising jingles for food make children demand for and consume excess food that may have negative implications on their health as against 3.3% that strongly disagreed. Also, 58.7% strongly agreed that catchy television advertising slogans and illustrations for food misguide children when making demands from parents, with respect to food purchase and consumption as against 1.9% that strongly disagreed. Finally, 53.6% strongly agreed that deceptive television advertising for food results in negative attitude development like pilferage and lie telling among children, with respect to food purchase and consumption.

### Test of Hypotheses and Discussions of Findings

#### Test of Hypothesis 1

**H0<sub>1</sub>:** television advertising jingle has no significant effect on food consumption among children.

**Table 7: For hypothesis 1, we specify Simple regression, thus;**

Variable	Parameters	Coefficient	Std error	Tcal – value
Constant	$\beta_0$	2.138	1.467	1.457
Television advertising jingles (TAJ)	$\beta_1$	1.042	0.180	5.788***
<b>R-Square (R<sup>2</sup>)</b>		0.671		
<b>Adjusted R – Square (R<sup>-2</sup>)</b>		0.665		
<b>F – Statistics</b>		44.068***		
<b>F -Probability</b>		0.000		

\*\*\*, \*\*, and \* denotes significance of coefficient at 1%, 5%, and 10% level respectively

**Source: Field Survey, 2018. (SPSS Version 20)**

The coefficient of television advertising jingle was statistically significant and positively related to food consumption among children at 1% level (5.788\*\*\*). This implies that television advertising jingle has positive and significant effect on food consumption among children.

The coefficient of multiple determination ( $R^2$ ) was 0.671 which implies that 67.1% of the variations in the dependent variable were explained by changes in the independent variable while 32.9% were explained by the stochastic terms in the model. This implies that the independent variable (television advertising jingles) can only explain 67.1% of changes in food consumption among children, leaving 32.9% percent unexplained. The  $R^2$  adjusted was 0.665% indicating a goodness of fit of the regression model adopted in this study which is statistically significant at 5% probability level. F-statistics of value 44.068 and F-probability value of 0.000 was observed from the analysis which is less than 0.05, indicating that the estimated regression model adopted in this study is statistically significant at 5% significant level. With this, the researcher rejected the null hypothesis, meaning television advertising jingle has a significant effect on food consumption among children in Umuahia Abia State, Nigeria.

### Test of Hypothesis 2

**H0<sub>2</sub>:** television advertising copy has no significant effect on food consumption among children

**Table 8:** For hypothesis 2, we specify simple regression, thus;

Variable	Parameters	Coefficient	Std error	Tcal – value
Constant	$\beta_0$	0.019	0.002	9.503***
Television advertising copies (TAC)	$\beta_2$	0.661	0.288	2.295**
<b>R-Square (<math>R^2</math>)</b>		0.469		
<b>Adjusted R – Square (<math>R^2</math>)</b>		0.455		
<b>F – statistics</b>		16.502***		
<b>F - probability</b>		0.001		

\*\*\*, \*\*, and \* denotes significance of coefficient at 1%, 5%, and 10% level respectively  
Source: Field Survey, 2018. (SPSS Version 20)

The coefficient of television advertising copy was statistically significant and positively related to food consumption among children at 5 percent level (2.295\*\*). This implies that a unit increase in television advertising copy leads to an increase in food consumption among children by 0.661 units. Thus, television advertising copy has significant effect on food consumption among children in Umuahia Abia State.

The result of coefficient of multiple determination ( $R^2$ ) was 0.569 which implies that 57% of the variations in dependent variable were explained by changes in the independent variable while 43% were unexplained by the stochastic variable, indicating a goodness of fit of the regression model adopted in this study which is statistically significant at 5% probability level. The F-statistics value of 16.052 and F-probability value of 0.001 was observed from the analysis which is less than 0.05, indicating that the estimated regression model adopted in this study is statistically significant at 5% significant level. With this, the researcher rejected the null hypothesis, television advertising copy has significant effect on food consumption among children in Umuahia Abia State, Nigeria.

### Test of Hypothesis 3

**H0<sub>3</sub>:** Television advertising settings has no significant effect on food consumption among children in Umuahia Abia State, Nigeria.

**Table 9:** for hypothesis 3, we specify simple regression, thus;

Variable	Parameters	Coefficient	Std error	Tcal – value
Constant	$\beta_0$	3248.260	334.855	9.700***
Television advertising setting (TAS)	$\beta_3$	0.165	0.036	4.621***
<b>R-Square (R<sup>2</sup>)</b>		0.483		
<b>Adjusted R – Square (R<sup>-2</sup>)</b>		0.477		
<b>F – statistics</b>		21.351***		
<b>F – probability</b>		0.000		

\*\*\*, \*\*, and \* denotes significance of coefficient at 1%, 5%, and 10% level respectively  
Source: Field Survey, 2018. (SPSS Version 20)

The estimate value of television advertising setting (TAS) of 0.165 shows that a unit increase in Television advertising setting, holding other variables constant will lead to an increase in food consumption among children by 0.165 units. By implication, television advertising setting has positive and significant effect on food consumption among children. The result conforms to *priori expectations* because children who eat their meals in front of the television tend to consume more dietary fat. This is because, the number of hours of television viewing by teenagers was significantly correlated with the number of unhealthy food items consumed per day.

The result of coefficient of multiple determination (R<sup>2</sup>) was 0.483 which implies that 48.3% of the variations in dependent variable were explained by changes in the independent variable while 51.7% were unexplained by the stochastic variable indicating a goodness of fit of the regression model adopted in this study which is statistically significant at 5% probability level. F-prob of value 21.351 and F-stat value of 0.000 was observed from the analysis which is less than 0.05, indicating that the estimated regression model adopted in this study is statistically significant at 5% significant level. With this, the researcher reject the null hypothesis meaning television advertising settings has significant effect on food consumption among children in Umuahia Abia State, Nigeria.

## Summary of Findings, Conclusion and Recommendations

### Summary of Findings

The study examined the effect of television advertising on food consumption among children in Umuahia, Abia State. In order to actualize the objectives, the hypotheses were tested and the major findings revealed by the study are highlighted and discussed as follows:

Major findings from the analysis of the questionnaire items based on the objectives:

- i. 62.3% of the respondents strongly agreed that children tend to demand for and consume excess sweets that may have negative implications on their health as a result of the captivating jingles in the advertisements of sweets;
- ii. 63.1% of the respondents strongly agreed that children are easily attracted to food products advertised with catchy slogans or phrases that appeal to their interests and emotions;
- iii. (60.7%) strongly agreed that most television advertisements for food products portray deceptive settings that make children demand for and consume food indiscriminately; and
- iv. 59.3% strongly agreed that captivating television advertising jingle for food makes children demand for and consume excess food that may have negative implications on their health.

Major findings from hypotheses tested:

- i. Television advertising jingle has a significant effect on food consumption among children in Umuahia Abia State;
- ii. Television advertising copy has a significant effect on food consumption among children in Umuahia Abia State, Nigeria; and
- iii. Television advertising setting has a significant effect on food consumption among children in Umuahia Abia State, Nigeria.

### Conclusion

Children are more vulnerable to television advertisements. Television is a persistent medium which is available to nearly all children all the time. Most children tend to spend much of their time daily watching television. Thus, it is desirable for the parents of young children to monitor the television viewing habits of their children. As a result, this study examined the effect of television advertising on food consumption among children in Umuahia, Abia State and the conclusion of the study based on findings is that television advertising jingle, copy and setting have significant effect on food consumption among children in Umuahia Abia State, Nigeria.

### Recommendations

Based on the findings and conclusion, the following recommendations are suggested:

1. Parents should teach their children how to react to television advertising jingles that relate to food consumption. This will help to reduce the effect of such jingles on children's demand for sweeties;
2. Parents should monitor the television viewing habit of their children (types of programmes the children watch and the number of hours they spend watching television daily). This will help to reduce the possibility of getting harmful information by television advertising copy; and
3. Parents should teach their children how to separate realities from imaginations and fantasies. This will reduce the possibility of the children by getting entangled by the deceitful advertising settings on food consumption.

### Contribution to Knowledge

The major contribution this work has made to knowledge is that, it has developed models for the study of effect of television advertising on food consumption among children. These models were modified from the original simple regression model stated as follows:  $Y = b_0 + b_1X$

To suit the variables in the study, the models developed are thus:

Model 1: FCAC = F(TAJ)

Hence FCAC =  $b_0 + b_1TAJ + e_i$

Where: FCAC = Food Consumption among Children

f = "function of"

TAJ = Television Adverting Jingles

$b_0$  = Constant

$b_1$  = Coefficient of TAJ

$e_i$  = Error Margin (5%)

Model 2 FCAC = f(TAC)

Hence FCAC =  $b_0 + b_1TAC + e_i$

Where: FCAC = Food Consumption among Children

f = "function of"

TAC = Television Adverting Copies

$b_0$  = Constant

$b_1$  = Coefficient of TAC

---

---

	$e_i$	= Error Margin (5%)
Model 3	$FCAC = f(TAS)$	
Hence	$FCAC = b_0 + b_1TAS + e_i$	
Where:	$FCAC$	= Food Consumption among Children
	$f$	= "function of"
	$TAS$	= Television Advertising Settings
	$b_0$	= Constant
	$b_1$	= Coefficient of $TAS$
	$e_i$	= Error Margin (5%)

## References

- Alam, G.M., and Khalifa, M.T.B (2009). Impact of introducing a business marketing approach to education: A Study on private HE in Bangladesh, *African Journal of Business Management*, 3(9), 463 – 474
- Asadollahi, A., and Tanha, N., (2011). The role of television advertising and its effect on children, *Interdisciplinary Journal of Research in Business*, 1(9), 1-6
- Blackwell, R.D., Miniard, P.W., and Engel, J.F. (2006). *Consumer Behaviour*, 10 edn. South-Western: Thomson Learning
- Buijzen, M., Schuurman, J., and Bomhof (2008). Association between children's television advertising exposure and their food consumption patterns: *A Household Diary-Survey Study*, *Appetite*, (50), 231 - 239
- Camargo, P. (2010). in Neto, A. R. V. and Serafim de Melo, L. G. N. (2013). Factors affecting children's food purchasing behavior. *Saude e Sociedade*, Print Version, 22(2), 1 – 14
- Child Development Institute (1991). Know your child better by learning the ages and stages of child development. America: *CDI*, 1 – 8
- Council for Cable Information (1984). National Federation of Local Cable Programmers, *Community Television Review*, 9(1986), 35
- Dibie, V. M. (2017). Children's influence strategies on family purchase decision making in Umuahia, Abia State, and Southeast Nigeria. EBSU-Abakaliki, Ph.D Thesis Unpublished 1 – 205.
- Douglas, L. (1998). Children's food choice. *Journal of Nutrition and Food Science*, 1:14 – 18
- Explore-channel4, <http://www.channel4.com> (Retrieved Online: 25/04/2018)
- Furham, A., Abramsky, S., and Gunter, B. (1997). A cross-cultural content analysis of children's television advertisements. *Sex Roles*, 37:91 – 99
- Hameed, A., Wagas, A., Aslam, M. N., Bilal, M. and Umair, M. (2014). Impact of television advertisements on children's buying behavior. *International Journal of Humanities and Social Sciences*, 4:241 – 258
- Hoerberichts, N. (2012). Music and Advertising: The effect of music in television commercials on consumer attitudes, Thesis, International Bachelor, Economics and Business Economics, Faculty of Economics and Business Marketing, Entrepreneurship and Organization, Erasmus University, Rotterdam.
- Ikeagwu, E.K. (1998). Groundwork of research methods and procedures, Enugu: Institute for Development Studies, UNEC
- Kelly B., Hattersley, L., King, L., and Flood, V. (2008). Persuasive food marketing to children: Use of cartoons and competitions in Australian commercial television advertisements, *Health Promotion International*, 23(4), 337 – 344
- Klien, I. D., Brown, J. D., Childers, K. W., Oliver, J. Porter, C., and Dykers, C. (1993). Adolescents' risky behaviours and mass media use. *Pediatrics*, 92 (24 – 31)
- Kotler, P. (1994). *Marketing Management Analysis, Planning, Implementation and Control*. 8edn., New Jersey: Prentice Hall International Edition



- Letona, P., Chacon, V., Roberto, C., and Barnoya, J. (2014). A quantitative study of children's snack food packaging perceptions and preferences, *B.M.C: Public Health*
- McNeal, J. U. (2002). *Children as consumers of commercial and social products*. Washington, D. C. Pan American Health Organization
- Neto, A. R. V., and Serafim de Melo, L. G. N. (2013). Factors affecting children's food purchasing behaviour. *Saude e Sociedade*, Print Version, 22(2) 1 – 14
- Nurudeen, T.S., and Ojoawo, O.O. (2001). *Inferential Statistics*, Lagos: Kamah and Associates 1– 370
- Nwokoye, N. G. (2000). *Modern Marketing for Nigeria, Principles and Practice*, Onitsha: Africana First Publishers Plc, 1 – 3
- Oliveira, (2003). in Neto, A. R. V. and Serafim de Melo, L. G. N. (2013). Factors affecting children's food purchasing behavior. *Saude e Sociedade*, Print version, 22(2), 1 – 14
- Petty, R.E., and Cacioppo, J.T. (1986). The elaboration likelihood model of persuasion, *Advances in Experimental Social Psychology*, 19 (123 – 180)
- Powell, L. M., Szez, G., and Chaloupka, J. (2007). Adolescent exposure to food advertising on television. *American Journal of Preventive Medicines*, 33 (251 – 256)
- Steward, D., and Furse, D., (1986). Analysis of the impact of executional factors on advertising performance, *Journal of Advertising Research*, 24(4), 23 – 26
- Steward, R.W. (1941). *Imagery for profit*, New York: New York Times, July 6 edn.
- Wallace, W.T. (1994). Memory for music: Effect of melody on recall of text, *Journal of Experimental Psychology*, 20(6), 1470 – 1485
- Wikipedia. Advertisement Film <http://en.wikipedia.org/windex.php>  
(Retrieved Online: 19/01/2018)
- Yalch, R. (1991). Memory in a jingle: Music as an mnemonic device in communication advertising slogans, *Journal of Applied Psychology*, 76(2), 268 – 275
- Yamane, T. (1967). *Elementary sampling theory*, Eaglewood Cliffs, New Jersey. Prentice Hall Line
- Yesser, M., and Faisal M., In Vimi, J. (2013). Cases of Consumer-Centric Marketing Management, *Advances in Marketing, Customer Relationship Management and E-Services (AMCRMES) Book Series*, Hersley Pennsylvania: IGI Global